

ACM135/150

Rooftop Air Conditioner



ACRG15-FlashFreezeCeilingAssembly

KEY FEATURES:

- Condensation Dispersion Cooling System
 - Increases cooling efficiency and eliminates water run-off
- 68lbs total weight
 - Over 20% lighter than traditional rooftop ACs

ADDITIONAL FEATURES:

- 13,500 BTU/hr (ACM135)
- 15,000 BTU/hr (ACM150)
- 115V AC power
- Non-ozone depleting refrigerant (R410a)
- Rigid, metal frame with thick foam support pads allows for quiet operation
- Premium, extra thick water seal gasket
- Three fan speeds (Low, Medium, High)
- Fan-On control option
- Installs on standard 14.25" x 14.25" vent opening
- Removable, washable filter

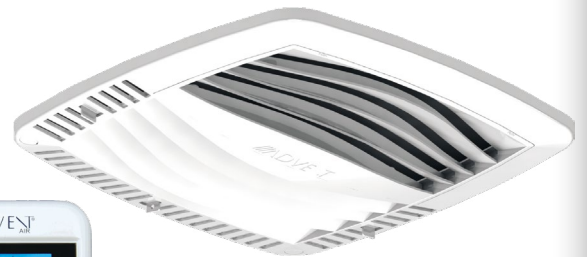

ACCARKIT
Carrier Replacement Kit



ACCOLKIT
Coleman Replacement Kit

ACM135/150

Rooftop Air Conditioner

TECHNICAL DATA

ACM135

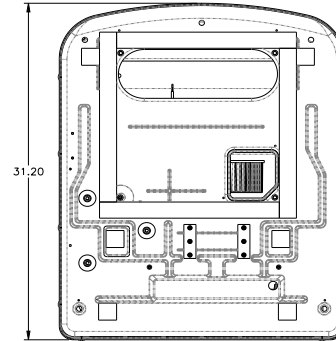
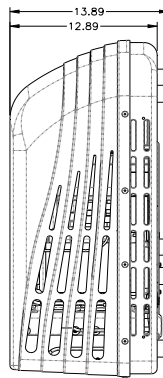
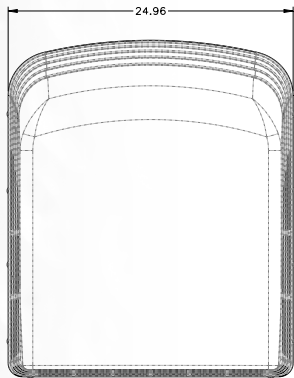

Features

- 13,500 BTU Rated Cooling Capacity
- R410a Refrigerant
- Compact Size
- Reduced weight
- High Efficiency (water dispersion cooling system)
- Low Noise
- Backwards compatible with all Advent ceiling assemblies

Specifications

General Specifications:

Power System	AC 115 V, 60 Hz	
Power Consumption	0W stand by	1450W rated
Overall Dimensions	24.9" W x 12.8" H x 31.2" D	
Product Weight (unpackaged)	68 lbs	
Regulatory Certification(s)	UL, CUL	

TECHNICAL DATA

ACM150

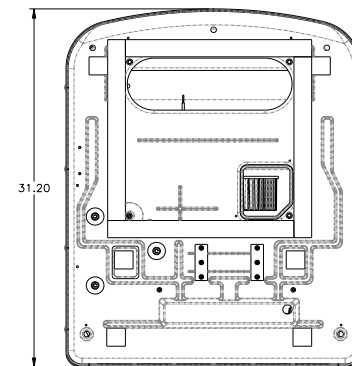
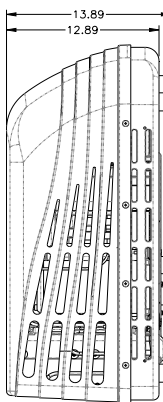
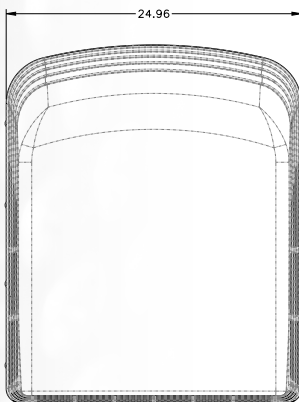

Features

- 15,000 BTU Rated Cooling Capacity
- R410a Refrigerant
- Compact Size
- Reduced Weight
- High Efficiency (water dispersion cooling system)
- Low Noise
- Backwards compatible with all Advent ceiling assemblies

Specifications

General Specifications:

Power System	AC 115 V, 60 Hz	
Power Consumption	0W stand by	1750W rated
Overall Dimensions	24.9" W x 12.8" H x 31.2" D	
Product Weight (unpackaged)	69 lbs.	
Regulatory Certification(s)	UL, CUL	