

Orderable Spare Part List

FURRION

Spare part list for:

Item	Product SKU Model	Product Name description
1	FWH09A	Water heater + Wall controller-OEM & After -sales market
2	FWH09EA-PS.OEM	Door 410 x 410mm-OEM
3	FWH41EA-PS.OEM	Door 410 x 460mm-OEM
4	FWH46EA-PS.OEM	Door 460 x 460mm-OEM
5	FWH09EA-PS.AM	Door 410 x 410mm-After -sales market
6	FWH41EA-PS.AM	Door 410 x 460mm-After -sales market
7	FWH46EA-PS.AM	Door 460 x 460mm-After -sales market

Team member	Name
ME	Lenny Liu
PE	Deric Deng
MERCH	Karl Fung
US Engineer	Daniel Putt

Last updated : 21-Sept-2020

Exploded Drawing

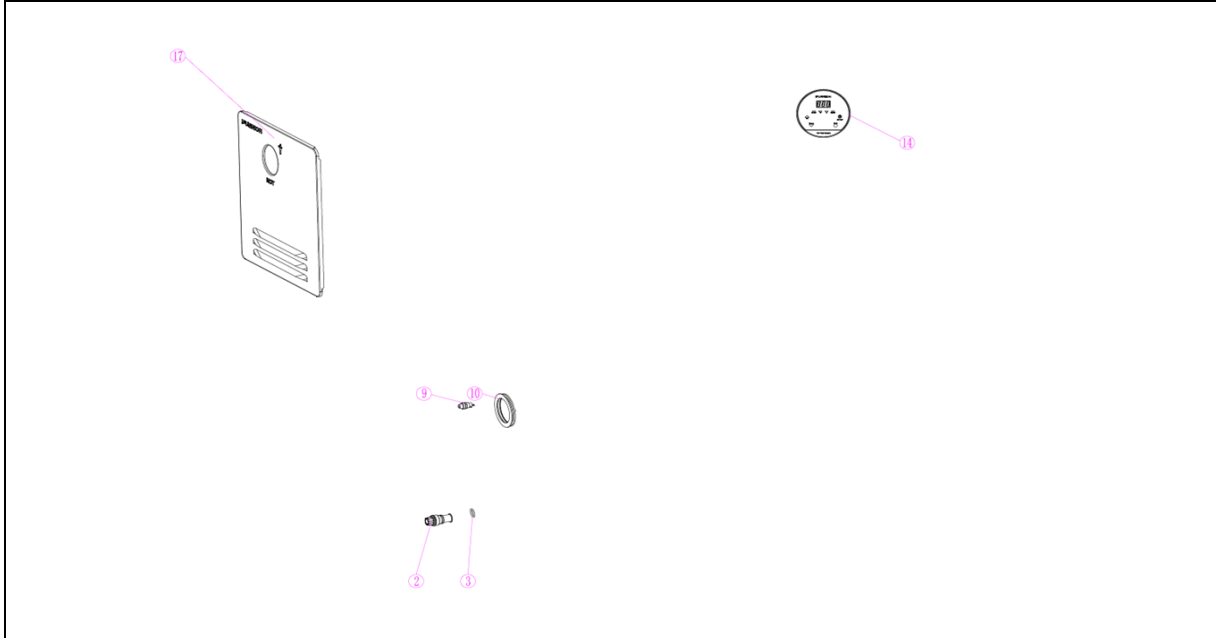

Index	Furrion part number	Spare Part Name	QTY (pc)	Applicable SKU Models	Orderable Spare Part	Remark
2, 3	C-FWH09A-005	Filter assembly	1	FWH09A	Y	
9	C-FWH09A-009	Fuse 10A / 125V (slow blow) 5 x 20mm	1	FWH09A	Y	
10	C-FWH09A-011	Flue duct seal	1	FWH09A	Y	
14	C-FWH09A-001	Wall Controller for Water Heater	1	FWH09A	Y	
17	C-FWH09A-013	Door panel - 410*410(Included DOE/Rating/Warning label)	1	FWH09EA-PS.OEM, FWH09EA-PS.AM	Y	

Orderable + B Stock Spare Part List

FURRION

Spare part list for:

Item	Product SKU Model	Product Name description
1	FWH09A	Water heater + Wall controller-OEM & After -sales market
2	FWH09EA-PS.OEM	Door 410 x 410mm-OEM
3	FWH41EA-PS.OEM	Door 410 x 460mm-OEM
4	FWH46EA-PS.OEM	Door 460 x 460mm-OEM
5	FWH09EA-PS.AM	Door 410 x 410mm-After -sales market
6	FWH41EA-PS.AM	Door 410 x 460mm-After -sales market
7	FWH46EA-PS.AM	Door 460 x 460mm-After -sales market

Team member	Name
ME	Lenny Liu
PE	Deric Deng
MERCH	Karl Fung
US Engineer	Daniel Putt

Last updated : 21-Sept-2020

Exploded Drawing

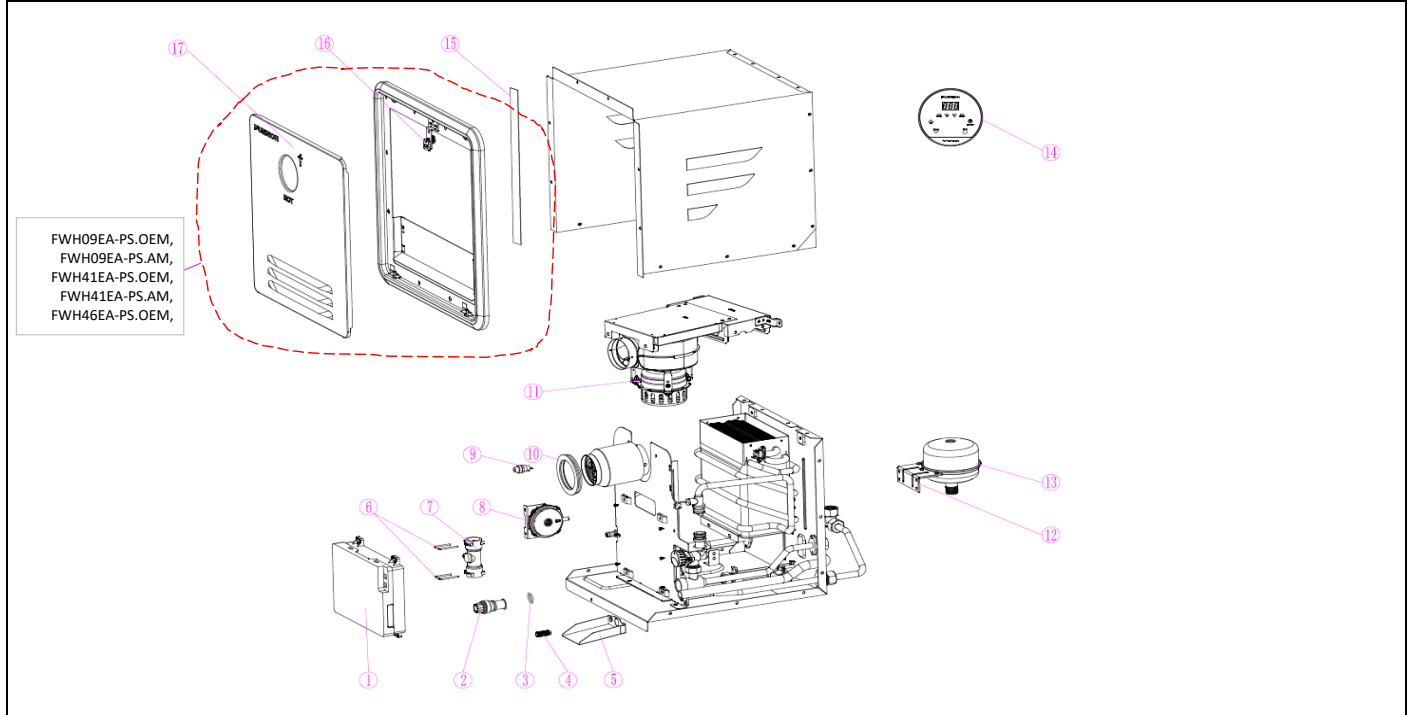

Index	Furrion part number	Spare Part Name	QTY (pc)	Applicable SKU Models	Orderable Spare Part	B Stock Spare Part	Remark
1	C-FWH09A-002	Controller Unit	1	FWH09A			
2,3	C-FWH09A-005	Filter assembly	1	FWH09A	Y	Y	
4	C-FWH09A-007	Drainpipe end plug	1	FWH09A		Y	
5	C-FWH09A-012	Drain exit channel	1	FWH09A		Y	
6,7	C-FWH09A-004	Water flow sensor assembly	1	FWH09A		Y	
8	C-FWH09A-006	Exhaust pressure switch	1	FWH09A		Y	
9	C-FWH09A-009	Fuse 10A / 125V (slow blow) 5 x 20mm	1	FWH09A	Y		
10	C-FWH09A-011	Flue duct seal	1	FWH09A	Y		
11	C-FWH09A-003	Flue fan assembly	1	FWH09A		Y	
12,13	C-FWH09A-008	Water tank	1	FWH09A		Y	
14	C-FWH09A-001	Wall Controller for Water Heater	1	FWH09A	Y		
15	C-FWH09A-014	Foam tape for door frame	1	FWH09A		Y	
16	C-FWH09A-010	Door locker assembly	1	FWH09EA-PS.OEM, FWH09EA-PS.AM, FWH41EA-PS.OEM, FWH41EA-PS.AM, FWH46EA-PS.OEM, FWH46EA-PS.AM		Y	
17	C-FWH09A-013	Door panel - 410*410(Included DOE/Rating/Warning label)	1	FWH09EA-PS.OEM, FWH09EA-PS.AM	Y		
17	C-FWH09A-015	Door panel - 410*460(Included DOE/Rating/Warning label)	1	FWH41EA-PS.OEM, FWH41EA-PS.AM		Y	
17	C-FWH09A-016	Door panel - 460*460(Included DOE/Rating/Warning label)	1	FWH46EA-PS.OEM, FWH46EA-PS.AM		Y	